

# TOGGLE LATCH

## HLD187-P

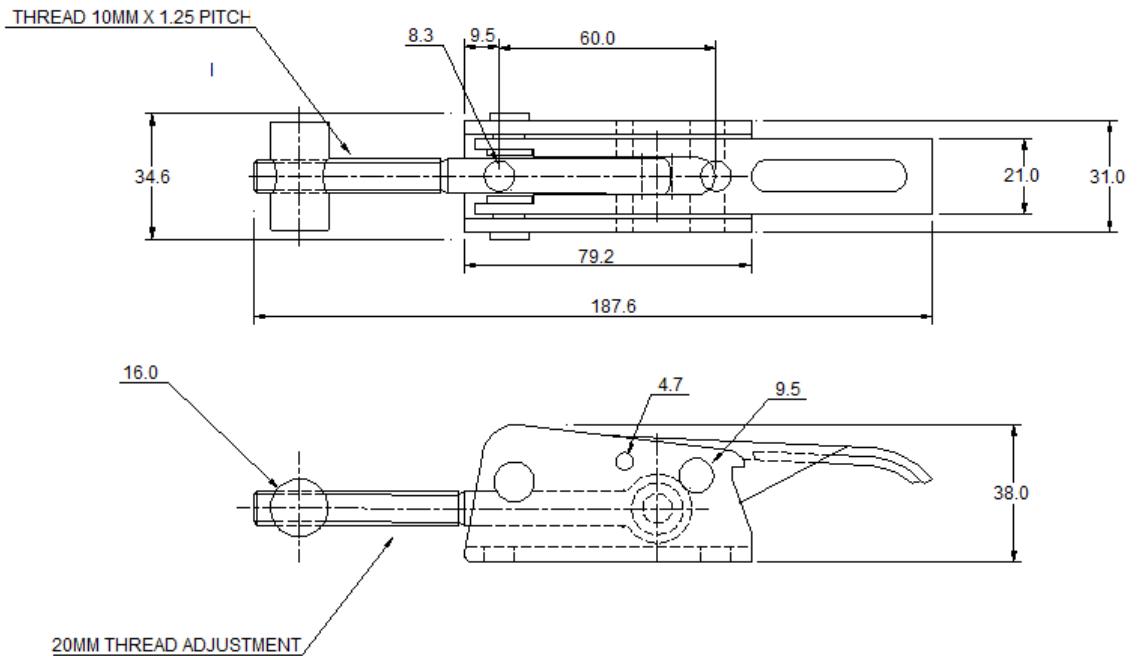

**Material:** Mild steel  
**Finish:** Zinc plate passivate (silver blue)  
**Weight:** 0.4156 Kg  
**Padlockable:** Yes  
**Safety:** No  
**Adjustment:** 20 mm\*  
**Strength/UTS:** 2000 Kg\*\*



### CATCH PLATE & ACCESSORIES

See PT NO: HLD187-CP

**Fix with 8mm low head socket cap screws**

\**Adjustment* – Provided by threaded claw or eyebolt. Adjustment allows for fitting tolerance and tension adjustment.

\*\**Strength /UTS* - The figures for the ultimate tensile strength (UTS) have been determined by tensile tests in a normal working load direction on standard products and do not include any safety factors. A maximum load rate of 30mm per minute was applied throughout the tests. The UTS figures are shown in Kilograms and for a safe working load we suggest that approximately half of the ultimate strength figure is used.