

# TOGGLE LATCH

## HL95-P

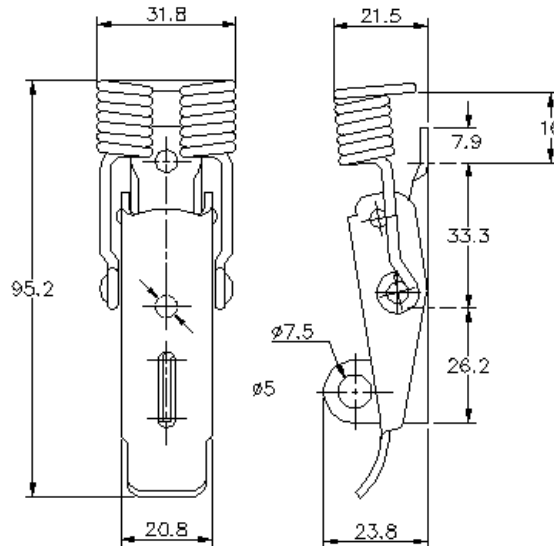

**Material:** Mild steel  
**Finish:** Zinc plate passivate (silver blue)  
**Hole Dia:** 5.1mm  
**Weight:** 0.0805 Kg  
**Padlockable:** Yes  
**Safety:** No  
**Spring:** 40@10.0mm\*  
**Strength/UTS:** 100 Kg\*\*

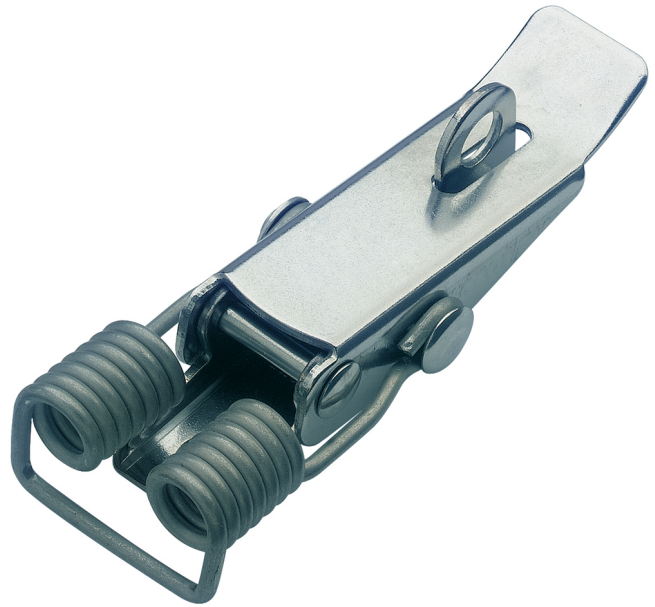

### CATCH PLATE & ACCESSORIES

See PT NO: HL01-CP  
HL02-CP

\*Spring - Max' working load (Kg) at max' spring deflection (mm)

\*\*Strength /UTS - The figures for the ultimate tensile strength (UTS) have been determined by tensile tests in a normal working load direction on standard products and do not include any safety factors. A maximum load rate of 30mm per minute was applied throughout the tests. The UTS figures are shown in Kilograms and for a safe working load we suggest that approximately half of the ultimate strength figure is used.