

AIR OPERATED PLUNGER CLAMPS

CP/AIR



CP9

Material: Heavy gauge steel
Hardened pins and bushes

Finishing: Zinc plated body
Copper plated plunger

Supplied with: 8x40mm spindle

Max Holding pressure: 500daN

Weight: 1.8Kgs

Operating air pressure: 4-6BAR

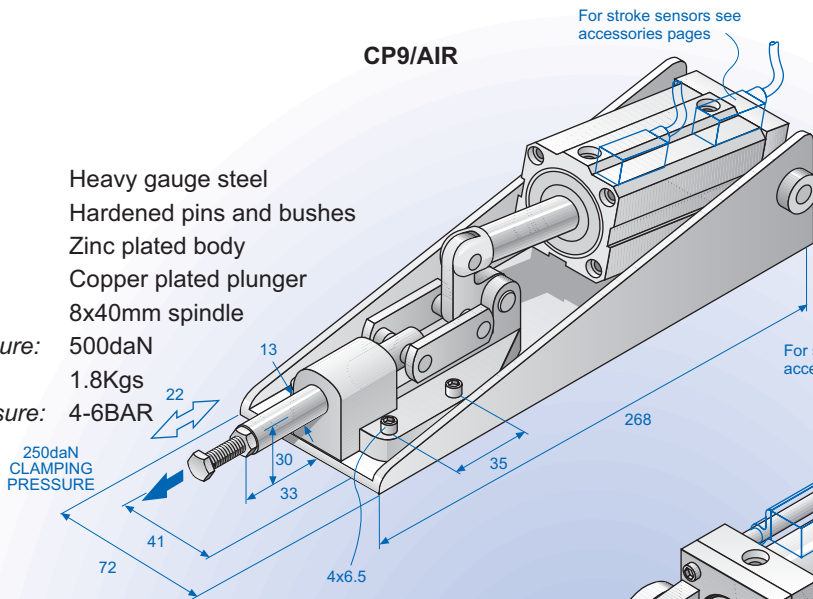

CP--/HO
Optional handle
to all models

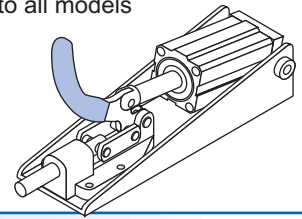

CP8

Material: Heavy gauge steel
Hardened pins and bushes

Finishing: Zinc plated body
Copper plated plunger

Supplied with: 10x50mm spindle

Holding pressure: 1000daN

Weight: 4Kgs

Operating air pressure: 4-6BAR

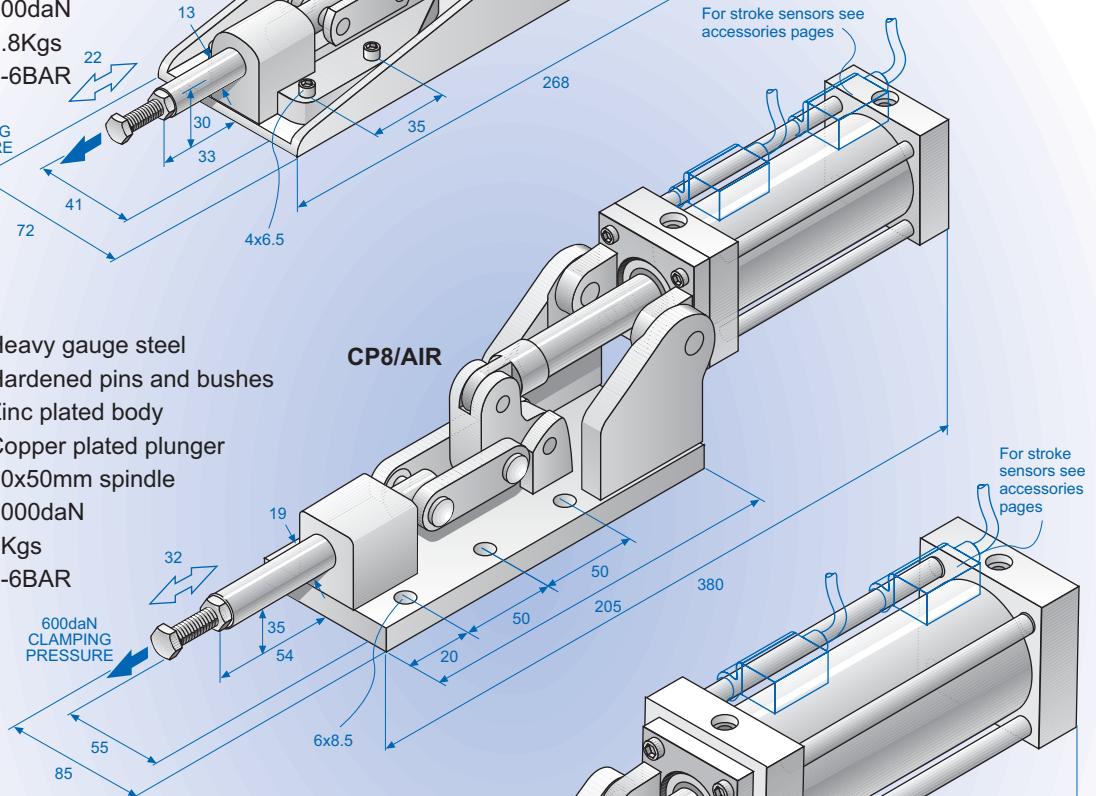

CP7

Material: Heavy gauge steel
Hardened pins and bushes

Finishing: Zinc plated body
Copper plated plunger

Supplied with: 12x60mm spindle

Holding pressure: 3000daN

Weight: 9Kgs

Operating air pressure: 4-6 BAR

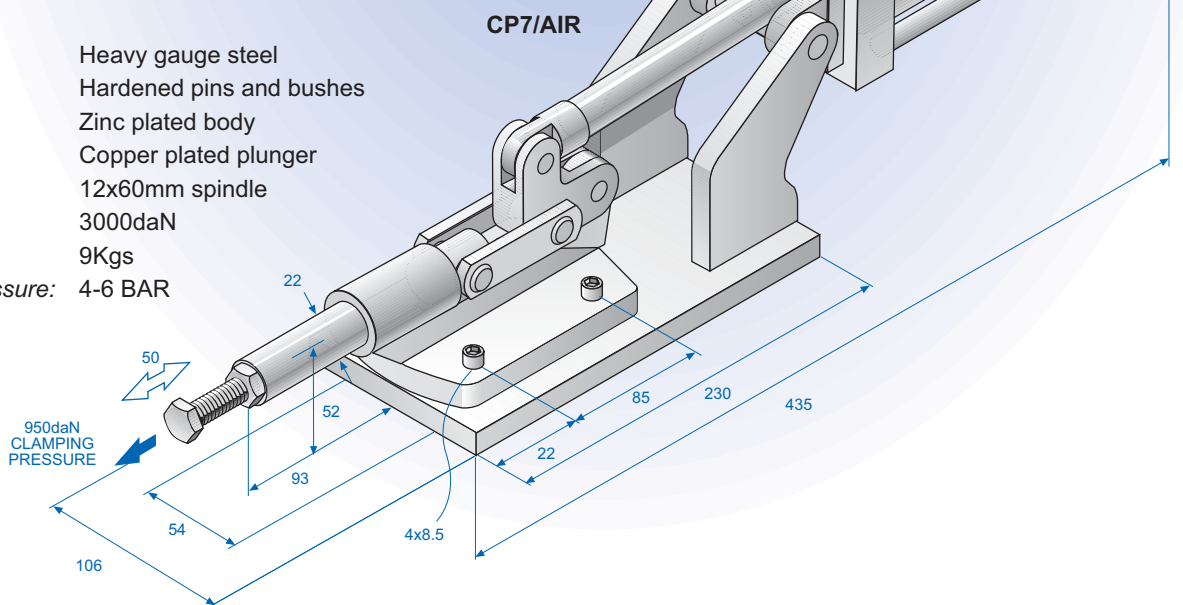

Please state at time of ordering if magnetic cylinders are required

Refer to accessory pages for further information